

Dell™ PowerVault™ Modular Disk 3000 Systems Installation Guide

www.dell.com | support.dell.com

Notes and Notices



NOTE: A NOTE indicates important information that helps you make better use of your computer.



NOTICE: A NOTICE indicates either potential damage to hardware or loss of data and tells you how to avoid the problem.

Information in this document is subject to change without notice.

© 2008 Dell Inc. All rights reserved.

Reproduction in any manner whatsoever without the written permission of Dell Inc. is strictly forbidden.

Trademarks used in this text: *Dell*, the *DELL* logo, and *PowerVault* are trademarks of Dell Inc.; *Intel* and *Pentium* are registered trademarks of Intel Corporation; *SUSE* is a registered trademark of Novell Inc.; *Microsoft*, *Windows*, and *Windows Server* are registered trademarks of Microsoft Corporation in the United States and other countries; *Red Hat* and *Red Hat Enterprise Linux* is a registered trademark of Red Hat Inc. in the United States and other countries

Other trademarks and trade names may be used in this document to refer to either the entities claiming the marks and names or their products. Dell Inc. disclaims any proprietary interest in trademarks and trade names other than its own.

October 2008

Contents

1	Introduction	5
	System Requirements	5
	Management Station Hardware Requirements	5
	Introduction to Storage Arrays	6
2	Hardware Installation	9
	Storage Configuration Planning	9
	About the Enclosure Connections	9
	Cabling the Enclosure	10
	Redundancy vs. Nonredundancy.	10
	Single SAS In Port Configurations	11
	Dual SAS In Port Configurations	15
	Expanding with Previously Configured MD1000 Enclosures	21
	Expanding with New MD1000 Enclosures	23
3	Software Installation	25
	System Assembly and Startup	25
	Installing MD Storage Manager	26
	Installing on Windows Systems	26
	Installing on Linux	30
	Documentation for Windows Systems	33

	Viewing the <i>PowerVault MD Documentation CD</i> Contents	33
	Installing the Manuals	34
	Documentation for Linux Systems	34
	Viewing the <i>PowerVault MD Documentation CD</i> Contents	34
	Installing the Manuals	36
4	Post-Installation Tasks	37
	Verifying Storage Array Discovery	41
	Load Balancing	41
	Load Balance Policy	41
	Setting Load Balance Policies in Linux	43
	Changing Load Balance Policies in Windows 2008	44
	Premium Features	45
	Troubleshooting Tools	45
5	Uninstalling Software	47
	Uninstalling From Windows	47
	Uninstalling From Linux	48
	Index	49

Introduction

This guide outlines the steps for configuring the Dell™ PowerVault™ Modular Disk 3000 (MD3000). This guide also covers installing MD Storage Manager software and the SAS 5/E Adapter Driver from the PowerVault MD3000 Resource CD, and the documentation from the *Dell PowerVault MD3000 Documentation* CD. Other information provided includes system requirements, storage array organization, initial software startup and verification, and discussions of utilities and premium features.

MD Storage Manager enables an administrator to configure and monitor storage arrays for optimum usability. MD Storage Manager operates on both Microsoft® Windows® and Linux operating systems and can send alerts about storage array error conditions by either e-mail or Simple Network Management Protocol (SNMP). These alerts can be set for instant notification or at regular intervals.

System Requirements

Before installing and configuring the MD3000 hardware and MD Storage Manager software, ensure that the operating system is supported and minimum system requirements are met. For more information, refer to the *Dell PowerVault MD3000 Support Matrix* available on support.dell.com.

Management Station Hardware Requirements

A management station uses MD Storage Manager to configure and manage storage arrays across the network. Any system designated as a management station must be an x86-based system that meets the following minimum requirements:

- Intel® Pentium® or equivalent CPU (133 MHz or faster)
- 128 MB RAM (256 MB recommended)
- 120 MB disk space available
- Administrator or equivalent permissions

- Minimum display setting of 800 x 600 pixels with 256 colors (1024 x 768 pixels with 16-bit color recommended)

Introduction to Storage Arrays

A storage array includes various hardware components, such as physical disks, RAID controller modules, fans, and power supplies, gathered into enclosures. An enclosure containing physical disks accessed through RAID controller modules is called a RAID enclosure.

One or more hosts attached to the array can access the data on the storage array. You can also establish multiple physical paths between the host(s) and the array so that the loss of any single path (through failure of a host port, for example) does not result in loss of access to the data stored on the array.

The storage array is managed by MD Storage Manager software running either on a host or on a storage management station. On a host system, MD Storage Manager and the array communicate management requests and event information directly via interface cables. On a storage management station, MD Storage Manager communicates with the array either through an Ethernet connection on the RAID controller modules or via the host agent installed on the host server.

With MD Storage Manager, you configure the physical disks in the array into logical components called *disk groups*. You can then divide the disk groups into *virtual disks*. You can make as many disk groups and virtual disks as your storage array configuration and hardware permit. Disk groups are created in the *unconfigured capacity* of a storage array and virtual disks are created in the *free capacity* of a disk group.

Unconfigured capacity is comprised of the physical disks not already assigned to a disk group. When a virtual disk is created using unconfigured capacity, a disk group is automatically created. If the only virtual disk in a disk group is deleted, then the disk group is also deleted. Free capacity is space in a disk group that has not been assigned to a virtual disk.

Data is written to the physical disks in the storage array using RAID technology. RAID levels define the way in which data is written to physical disks. Different RAID levels offer different levels of accessibility, redundancy, and capacity. You can set a specified RAID level for each disk group and virtual disk on your storage array.

You can provide an additional layer of data redundancy by creating hot spares in a disk group that has a RAID level other than 0. Hot spares can automatically replace physical disks marked as Failed.

2

Hardware Installation

This chapter provides guidelines for planning the physical configuration of your Dell™ PowerVault™ MD3000 storage array and for connecting one or more hosts to the array. For complete information on hardware configuration, see the *Dell PowerVault MD3000 Hardware Owner's Manual*.

Storage Configuration Planning

Consider the following items before installing your storage array:

- Evaluate data storage needs and administrative requirements.
- Calculate availability requirements.
- Decide the frequency and level of backups, such as weekly full backups with daily partial backups.
- Consider storage array options, such as password protection and e-mail alert notifications for error conditions.
- Design the configuration of virtual disks and disk groups according to a data organization plan. For example, use one virtual disk for inventory, a second for financial and tax information, and a third for customer information.
- Decide whether to allow space for hot spares, which automatically replace failed physical disks.
- If you will use premium features, consider how to configure virtual disk copies and snapshot virtual disks.

About the Enclosure Connections

The RAID array enclosure is connected to a host via two hot-pluggable RAID controller modules. The RAID controller modules are identified as RAID controller module 0 and RAID controller module 1 (see the *PowerVault MD3000 Hardware Owner's Manual* for more information).

Each RAID controller module has at least one SAS In port connector that provides the direct connection to the host or node. A second SAS In port connector is available on the optional dual-port RAID controller. SAS In port connectors are labeled **In-0** and, if using the optional controller, **In-1** (see the *PowerVault MD3000 Hardware Owner's Manual* for more information).

Each MD3000 RAID controller module also contains a SAS Out port connector. This port allows you the option to connect the RAID enclosure to an expansion enclosure.

 **NOTE:** When you cable from a host server to an MD3000 SAS In port connector, either Out port connector of the server's HBA can be used.

Cabling the Enclosure

You can cable your enclosure to up to four hosts and up to two expansion enclosures. The configuration that you choose depends on the number of hosts you have, whether you are connecting to a standalone host or a cluster node, and the level of data redundancy that you need.

The figures that follow are grouped according to the number of SAS In port connectors available on the MD3000. Single SAS In port configurations and dual SAS In port configurations each support redundant and non-redundant cabling.

Redundancy vs. Nonredundancy

Nonredundant configurations, configurations that provide only a single data path from a host to the RAID enclosure, are recommended only for non-critical data storage. Path failure from a failed or removed cable, a failed host bus adapter, or a failed or removed RAID controller module results in loss of host access to storage on the RAID enclosure.

Redundancy is established by installing separate data paths between the host and the storage array, in which each path is to different RAID controller modules. Redundancy protects the host from losing access to data in the event of path failure, because both RAID controllers can access all the disks in the storage array.

Single SAS In Port Configurations

Figure 2-1 through Figure 2-5 show supported nonredundant and redundant cabling configurations to MD3000 RAID controller modules with a single SAS In port connector. Each diagram shows the maximum number of optional expansion enclosures attached.

Figure 2-1 through Figure 2-3 show one and two hosts, each connected to only one RAID controller module that is subsequently expanded to two more storage enclosures. The hosts can share storage space but without redundant paths, if one path were to fail, the server on that path would be disconnected from the storage array.

Figure 2-1. Cabling One Host With Nonredundant Data Paths

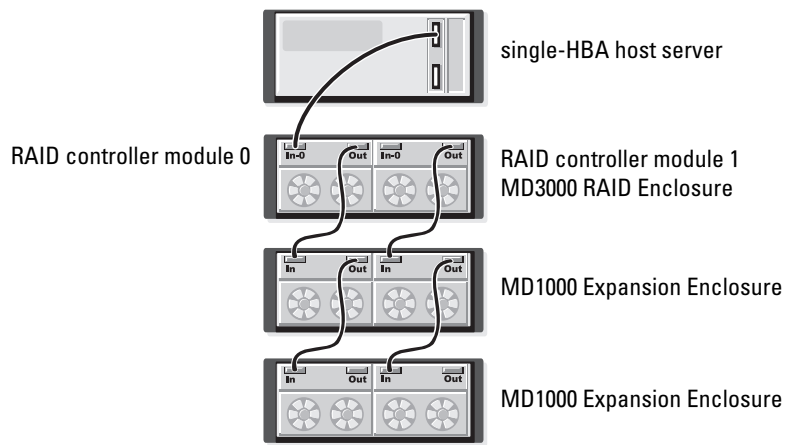

Figure 2-2. Cabling Two Hosts With Nonredundant Data Paths

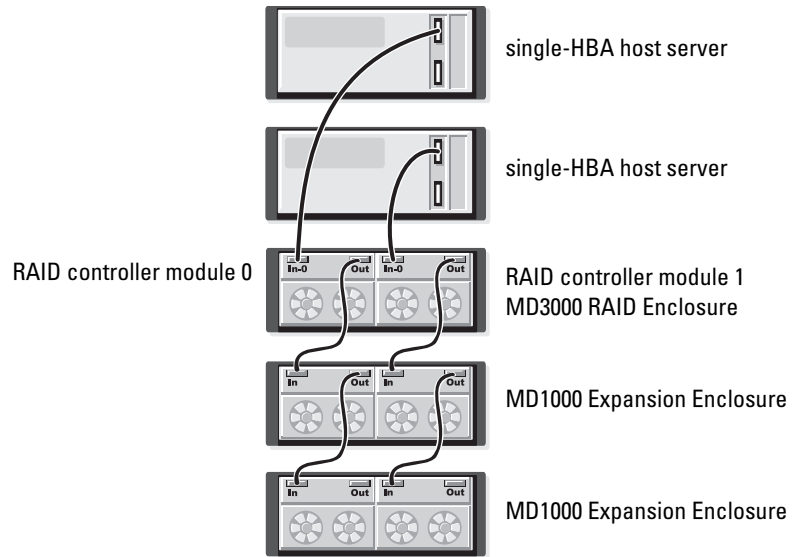

Figure 2-3. Cabling a Two-Node Cluster (Single HBA, Nonredundant Data Paths From Each Node)

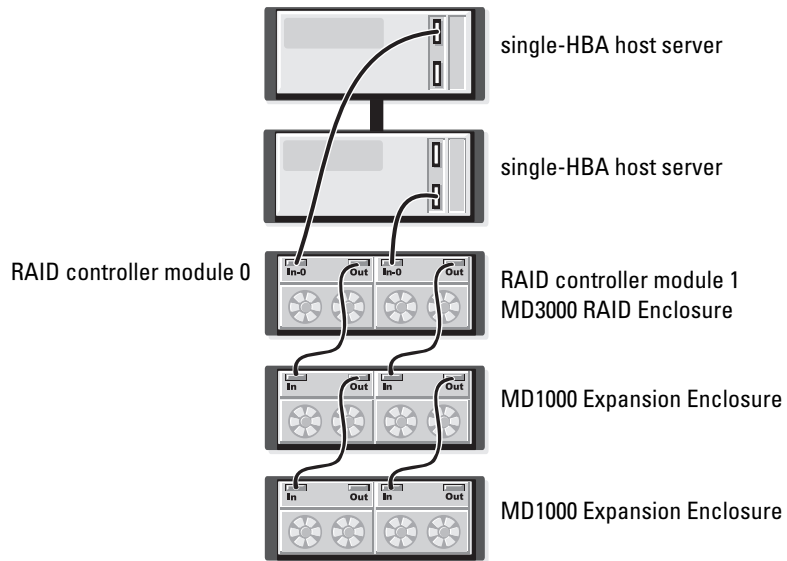

Figure 2-4 and Figure 2-5 show redundant, high-availability cabling configurations for one and two hosts. If any one path fails, at least one HBA is still connected to one RAID controller.

Figure 2-4. Cabling a Single Host (Dual-HBA With Two Cable Connections) Using Redundant Data Paths

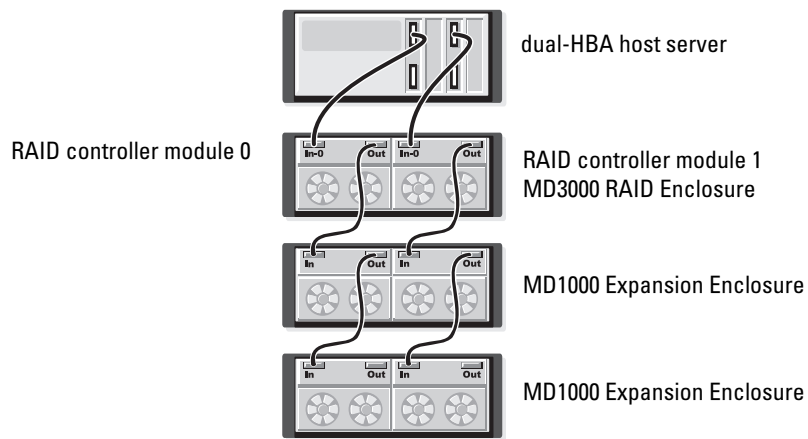
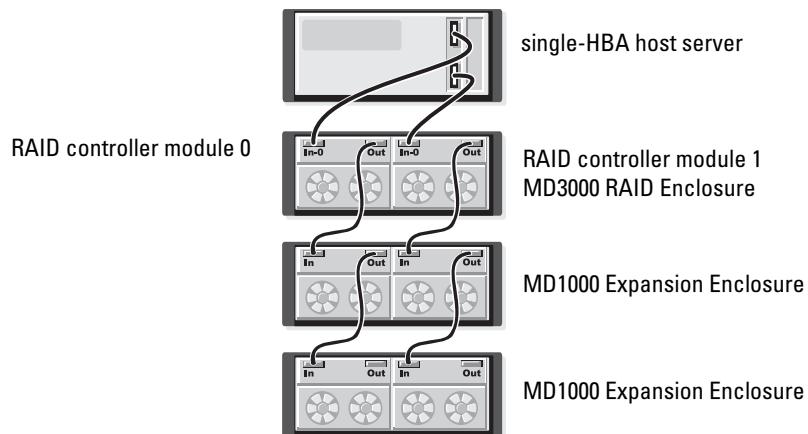

Figure 2-5. Cabling a Single Host (Single-HBA) Using Redundant Data Paths



Dual SAS In Port Configurations

Figure 2-6 through Figure 2-12 show supported nonredundant and redundant cabling configurations to MD3000 RAID controller modules with two SAS In port connectors. Each diagram shows the maximum number of optional expansion enclosures attached.

Figure 2-6 shows how one, two, three, and four hosts can each be connected to a RAID controller module nonredundantly. The RAID controller module is subsequently expanded to two more storage enclosures. The hosts can share storage space but without redundant paths, if one path were to fail, the server on that path would be disconnected from the storage array.

Figure 2-6. Cabling Up to Four Hosts With Nonredundant Data Paths

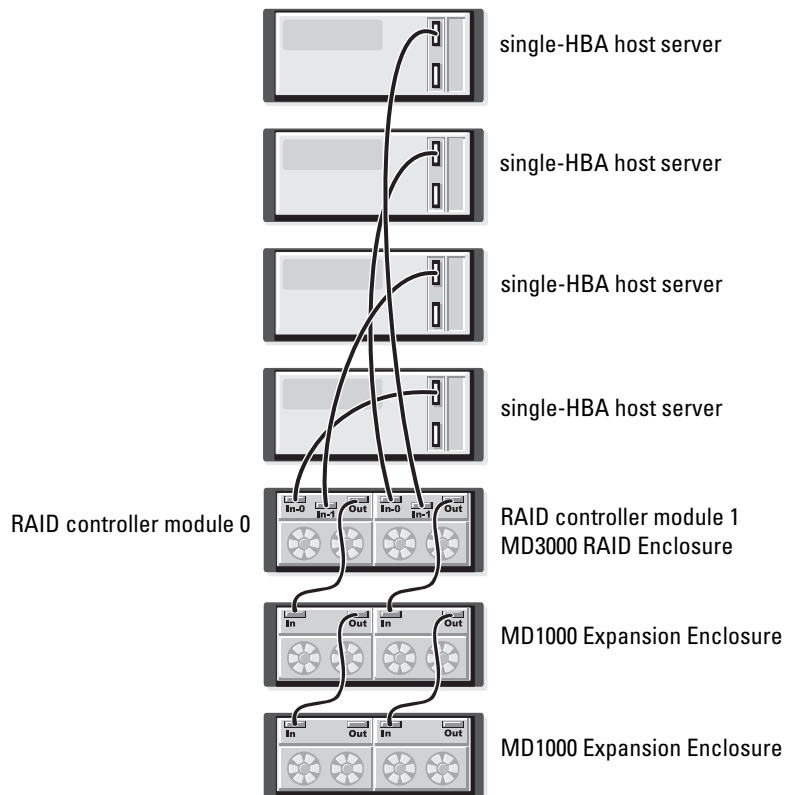

Figure 2-7 through Figure 2-10 show redundant, high-availability cabling configurations for one and two hosts. If any one path fails, at least one HBA is still connected to one RAID controller.

Figure 2-7. Cabling a Single Host (Dual-HBA With Four Cable Connections) Using Redundant Data Paths

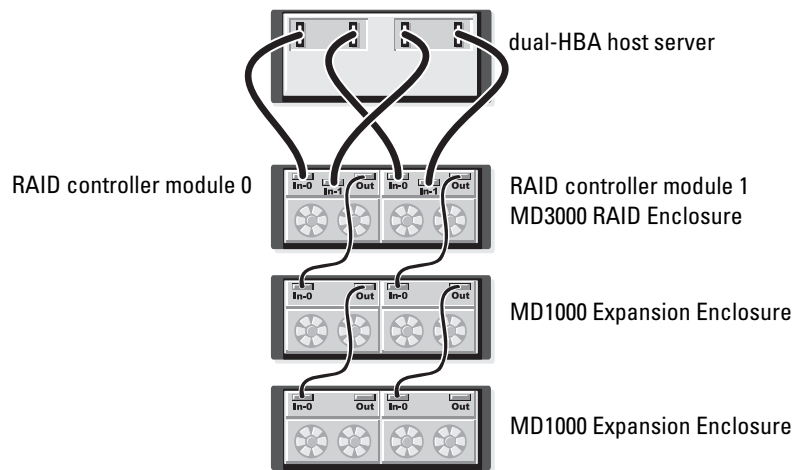

Figure 2-8. Cabling a Single Host (Single-HBA) Using Redundant Data Paths

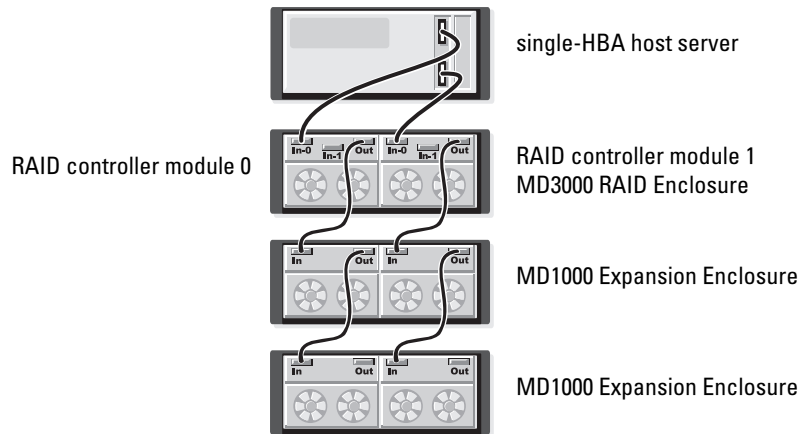

Figure 2-9. Cabling Two Hosts (With Dual-HBAs) Using Redundant Data Paths

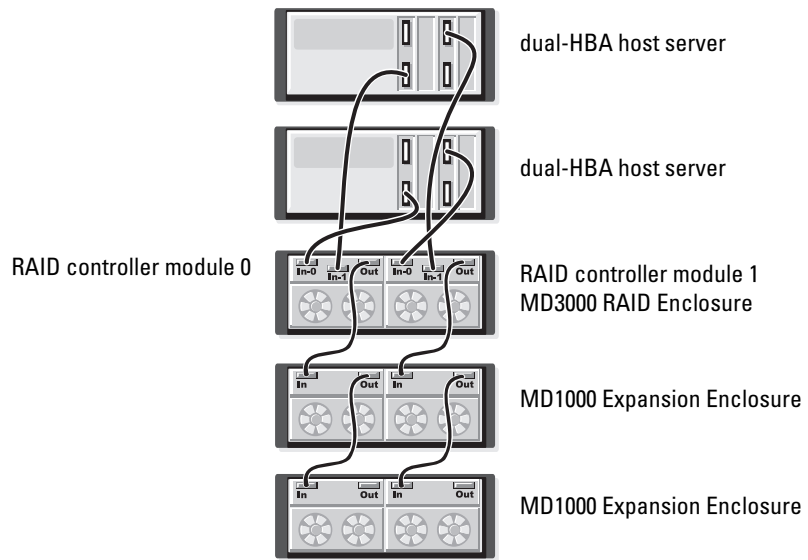

Figure 2-10. Cabling Two Hosts (With Single-HBAs) Using Redundant Data Paths

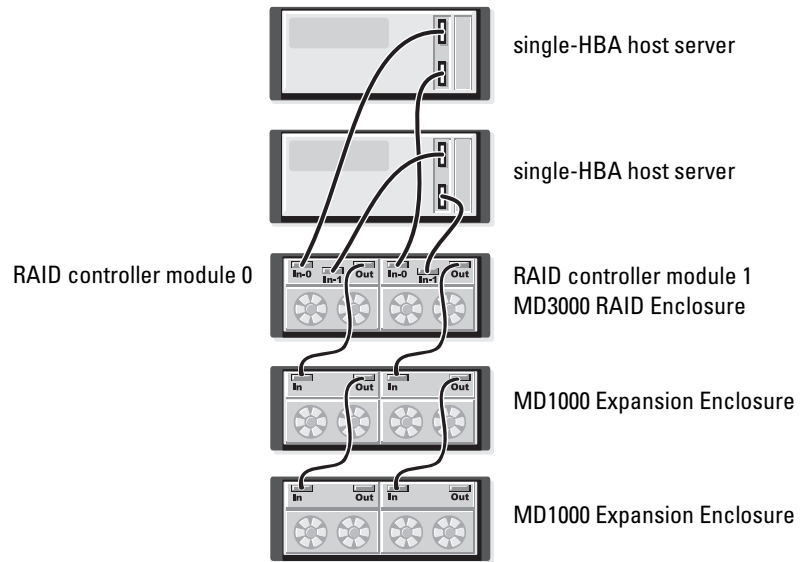

Figure 2-11 through Figure 2-12 show redundant, two-node cluster configurations using a single RAID enclosure that is subsequently expanded to two more storage enclosures.

Figure 2-11. Cabling a Two-Node Cluster (Single HBA, Redundant Data Paths From Each Node)

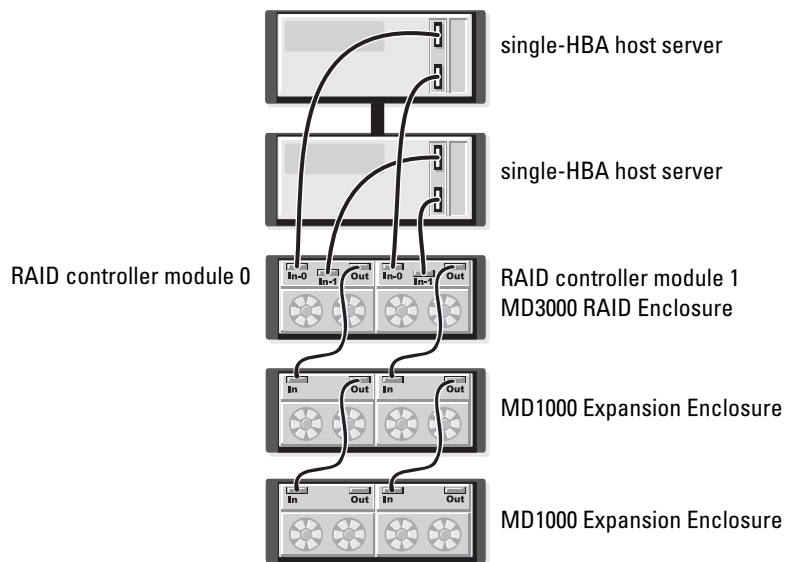
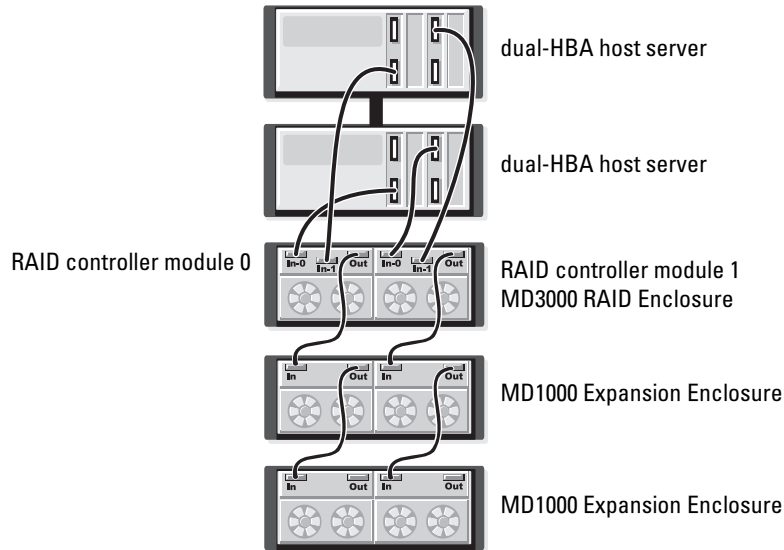

Figure 2-12. Cabling a Two-Node Cluster (Dual HBA, Redundant Data Paths From Each Node)



For a more detailed discussion of redundancy and nonredundancy, as well as alternate path software, see the *PowerVault MD3000 Hardware Owner's Manual*.

One of the features of the MD3000 is the ability to add up to two MD1000 expansion enclosures for additional capacity. This expansion increases the maximum physical disk pool to 45 3.5" SAS and/or SATA II physical disks.

As described in the following sections, you can expand with either a brand new MD1000 or an MD1000 that has been previously configured in a direct-attach solution with a PERC 5/E system.

➡ NOTICE: Ensure that all MD1000 expansion enclosures being connected to the MD3000 are updated to the latest Dell MD1000 EMM Firmware from support.dell.com. Dell MD1000 EMM Firmware versions prior to A03 are not supported in an MD3000 array; attaching an MD1000 with unsupported firmware causes an uncertified condition to exist on the array. See the following procedure for more information.

- ➡ **NOTICE:** MD1000 expansion enclosures that were connected to a PERC 5/E Adapter may contain Maxtor SAS hard disk drives, which are not supported in MD3000 or MD1000 expansion enclosures that are cabled to the MD3000. Ensure that all Maxtor SAS hard disk drives are removed from the MD1000 prior to attaching the enclosure to the MD3000.

Expanding with Previously Configured MD1000 Enclosures

Use this procedure if your MD1000 is currently directly attached to and configured on a Dell PERC 5/E system. Data from virtual disks created on a PERC 5 SAS controller cannot be directly migrated to an MD3000 or to an MD1000 expansion enclosure connected to an MD3000.

- ➡ **NOTICE:** If an MD1000 that was previously attached to PERC 5 SAS controller is used as an expansion enclosure to an MD3000, the physical disks of the MD1000 enclosure will be reinitialized and data will be lost. All MD1000 data must be backed up before attempting the expansion.

Perform the following steps to attach previously configured MD1000 expansion enclosures to the MD3000:

- 1 Back up all data on the MD1000 enclosure(s).
- 2 While the enclosure is still attached to the PERC 5 controller, upgrade the MD1000 firmware to an A03 or higher configuration. Windows systems users can reference the **DUP.exe** package; for Linux kernels, users can reference the **DUP.bin** package.
- 3 Before adding the MD1000 enclosure(s), make sure the MD3000 software is installed and up to date. For more information, refer to the *Dell PowerVault MD3000 Support Matrix* available on support.dell.com.
 - a Install or update the SAS driver and firmware. For Windows systems users, use the update package. For Linux systems users, use the DKMS package.
 - b Install or update (to the latest version available on support.dell.com) the MD Storage Manager on each host server. Install or update (to the latest version available on support.dell.com) the multipath drivers on each host server. The multipath drivers are bundled with Modular Disk Storage Management install. On Windows systems, the drivers are automatically installed when a Full or Host selection is made.

Expanding with New MD1000 Enclosures

Perform the following steps to attach new MD1000 expansion enclosures to the MD3000:

- 1** Before adding the MD1000 enclosure(s), make sure the MD3000 software is installed and up to date. For more information, refer to the *Dell PowerVault Support Matrix* available on support.dell.com.
 - a** Install or update the SAS driver and firmware. For Windows systems users, use the update package. For Linux systems users, use the DKMS package.
 - b** Install or update (to the latest version available on support.dell.com) the MD Storage Manager on each host server.
 - c** Install or update (to the latest version available on support.dell.com) the multipath drivers on each host server. The multipath drivers are bundled with Modular Disk Storage Management install. On Windows systems, the drivers are automatically installed when a Full or Host selection is made.
 - d** Using the MD Storage Manager, update the MD3000 RAID controller firmware (**Support**→ **Download Firmware**→ **Download RAID Controller Module Firmware**) and the NVSRAM (**Support**→ **Download Firmware**→ **Download RAID Controller Module NVSRAM**).
- 2** Stop I/O and turn off all systems:
 - a** Stop all I/O to the array and turn off affected host systems attached to the MD3000.
 - b** Turn off the MD3000.
 - c** Turn off any MD1000 enclosures in the affected system.
- 3** Referencing the applicable configuration for your rack (Figure 2-1 through Figure 2-12), cable the MD1000 enclosure(s) to the MD3000.
- 4** Turn on attached units:
 - a** Turn on the MD1000 expansion enclosure(s). Wait for the expansion status LED to light blue.

- b** Turn on the MD3000 and wait for the status LED to indicate that the unit is ready:
 - If the status LEDs light a solid amber, the MD3000 is still coming online.
 - If the status LEDs are blinking amber, there is an error that can be viewed using the MD Storage Manager.
 - If the status LEDs light a solid blue, the MD3000 is ready.
 - c** After the MD3000 is online and ready, turn on any attached host systems.
- 5** Using the MD Storage Manager, update all attached MD1000 firmware if it is out of date:
- a** Select **Support**→ **Download Firmware**→ **Download Environmental (EMM) Card Firmware**.
 - b** Check the **Select All** check box so that all attached MD1000 enclosures are updated at the same time (each takes approximately 8 minutes to update).

Software Installation

The *PowerVault MD Documentation* CD contains all documentation pertinent to MD3000 hardware and MD Storage Manager software. The *MD3000 Resource* CD contains software and drivers for both Linux and Microsoft® Windows® operating system users. Place this CD in the drive to install software or to install or use any of the items on the CD.

The *MD3000 Resource* CD also contains a **readme.txt** file covering both Linux and Windows operating systems. The **readme.txt** file contains information regarding changes to the software, updates, fixes, patches, and other important data for both Windows and Linux users. The **readme.txt** file also specifies software required for reading documentation on the CD or installed on a system, information regarding the versions of the software on the CD, and system requirements for running the software.

For more information on supported hardware and software for Dell™ PowerVault™ MD3000 systems, refer to the *Dell PowerVault MD3000 Support Matrix* located at support.dell.com.



NOTE: Dell recommends installing all the latest updates available at support.dell.com.

System Assembly and Startup

Use the following procedure to assemble and start your system for the first time:

- 1 Install the SAS 5/E Host Bus Adapter(s) in each host that you attach to the MD3000 Storage Array, unless the host bus adapter was factory installed.
- 2 Cable the storage array to the host(s).
- 3 Cable the Ethernet ports on the storage array to the network.
- 4 Start up the MD3000 storage array and wait 2 minutes for the array to initialize.
- 5 Start up each host that is cabled to the storage array.

See "About the Enclosure Connections" on page 9 for more information on hardware installation.

Installing MD Storage Manager

The MD Storage Manager software installation program allows you to select and install the storage array host software and the tools required to configure, manage, and monitor a storage array. To begin installing MD Storage Manager, insert the CD in the system drive.

 **NOTE:** Before installing and configuring the MD3000 and the MD Storage Manager software, review the documentation on the *PowerVault MD Documentation CD*. After installation, start the software to make sure it has been installed correctly, and then proceed to the post-installation configuration tasks.

Installing on Windows Systems

If you are running Windows 2003 or Windows 2008 operating systems, install the Microsoft Hotfix software on the host before installing the MD Storage Manager software. The hotfix is located in the `\windows\Windows_2003_2008\hotfixes` directory on the *MD3000 Resource CD*.

You must have administrative privileges to install MD Storage Manager files and program packages to the `C:\Program Files\Dell\MD Storage Manager` directory.

Complete the following steps:



- 1 Close all other programs before installing any new software.
- 2 Insert the CD, if necessary, and navigate to the main menu.

 **NOTE:** If the host server is running Windows Server 2008 Core version, navigate to the CD drive and run the `setup.bat` utility.

Host Installation

Follow these steps to install MD Storage Manager software on a system physically connected to the storage array.

- 1 If necessary, install the SAS 5/E Adapter Driver.
 - a Click the **Install the SAS 5/E Adapter Driver** bar on the main menu. The Installation Wizard appears.
 - b Follow the instructions on each screen.

- c After you click **Install**, the **Status** screen shows the progress of the installation. When it shows that installation is complete, click **Finish** to return to the main menu.
- 2** From the main menu, select **Install MD3000 Storage Software**.
The Installation Wizard appears.
- 3** Click **Next**.
- 4** Accept the terms of the License Agreement, and click **Next**.
The screen shows the default installation path.
- 5** Click **Next** to accept the path, or enter a new path and click **Next**.
- 6** Select an installation type:
 - **Typical (Full installation)** — This package installs both the management station and host software. It includes the necessary host-based storage agent, multipath driver, and MD Storage Manager software. Select this option if the host will also configure, manage, and monitor the storage array.
 - **Host** — This package installs the necessary storage agent and multipath driver on a host physically connected to the storage array. Select this option on all hosts that are connected to a storage array but will not use MD Storage Manager.
-  **NOTE:** Dell recommends using the host installation type if the host server is running Windows Server 2008 Core version.
- 7** Click **Next**.
- 8** If the **Overwrite Warning** dialog appears, click **OK**. The software currently being installed automatically replaces any existing versions of MD Storage Manager.
- 9** If you selected typical (full) installation in step 6, a screen appears asking whether to restart the event monitor automatically or manually after rebooting. You should configure only one system (either a host or a management station) to automatically restart the event monitor.
 -  **NOTE:** The event monitor notifies the administrator of problem conditions with the storage array. MD Storage Manager can be installed on more than one system, but running the event monitor on multiple systems can cause multiple alert notifications to be sent for the same error condition. To avoid this issue, enable the event monitor only on a single system that monitors your

MD3000 arrays. For more information on alerts, the event monitor, and manually restarting the event monitor, see the *MD Storage Manager User's Guide*.

- 10 The **Pre-Installation Summary** screen appears, showing the installation destination, the required disk space, and the available disk space. If the installation path is correct, click **Install**.
- 11 When the installation completes, click **Done**.
- 12 A screen appears asking if you want to restart the system now. Select **No, I will restart my system myself**.
- 13 If you are setting up a cluster host, double-click the **MD3000 Stand Alone to Cluster.reg** file located in the **utility** directory of the MD3000 Resource CD. This merges the file into the registry of each node.

 **NOTE:** Windows clustering is supported on Windows Server 2003 and Windows Server 2008.

If you are reconfiguring a cluster node into a stand alone host, double-click the **MD3000 Cluster to Stand Alone.reg** file located in the **windows\utility** directory of the *MD3000 Resource CD*. This merges the file into the host registry.

 **NOTE:** These registry files set the host up for the correct failback operation.

- 14 If you have third-party applications that use the Microsoft Volume Shadow-copy Service (VSS) or Virtual Disk Service (VDS) Application Programming Interface (API), install the VDS_VSS package located in the **windows\VDS_VSS** directory on the MD3000 Resource CD. Separate versions for 32-bit and 64-bit operating systems are provided. The VSS and VDS provider will engage only if it is needed.
- 15 Set the path for the command line interface (CLI), if required. See the *MD Storage Manager CLI Guide* for more information.
- 16 Install MD Storage Manager on all other hosts attached to the MD3000 array.
- 17 If you have not yet cabled your MD3000 Storage Array, do so at this time.
- 18 After the MD3000 has initialized, reboot each host attached to the array.

Management Station Installation

Follow these steps to install MD Storage Manager software on a system that will configure and manage a storage array over the network.

- 1** From the main menu, select **Install MD3000 Storage Manager Software**.
The Installation Wizard appears.
- 2** Click **Next**.
- 3** Accept the terms of the License Agreement and click **Next**.
The screen shows the default installation path.
- 4** Click **Next** to accept the path, or enter a new path and click **Next**.
- 5** Select **Management Station** as the installation type. This option installs only the MD Storage Manager software used to configure, manage and monitor a MD3000 storage array.
- 6** Click **Next**.
- 7** If the **Overwrite Warning** dialog appears, click **OK**. The software currently being installed automatically replaces any existing versions of MD Storage Manager.
- 8** A screen appears asking whether to restart the event monitor automatically or manually after rebooting. You should configure only one system (either a host or a management station) to automatically restart the event monitor.
 -  **NOTE:** The event monitor notifies the administrator of problem conditions with the storage array. MD Storage Manager can be installed on more than one system, but running the event monitor on multiple systems can cause multiple alert notifications to be sent for the same error condition. To avoid this issue, enable the event monitor only on a single system that monitors your MD3000 arrays. For more information on alerts, the event monitor, and manually restarting the event monitor, see the MD Storage Manager *User's Guide*.
- 9** The **Pre-Installation Summary** screen appears showing the installation destination, the required disk space, and the available disk space. If the installation path is correct, click **Install**.
- 10** When the installation completes, click **Done**.
A screen appears asking if you want to restart the system now.
- 11** Restart the system.
- 12** Set the path for the command line interface (CLI), if required. See the *MD Storage Manager CLI Guide* for more information.

Installing on Linux

MD Storage Manager can be installed and used only on Linux distributions that utilize the RPM Package Manager format, such as Red Hat[®] or SUSE.[®] The installation packages are installed by default in the `/opt/dell/mdstoragemanager` directory.

 **NOTE:** Root privileges are required to install the software.

- 1 Close all other programs before installing any new software.
- 2 Insert the CD. For some Linux installations, when you insert a CD into a drive, a screen appears asking if you want to run the CD. Select **Yes** if the screen appears. Otherwise, run `./install.sh` from the `linux` directory on the CD.

 **NOTE:** On the Red Hat Enterprise Linux 5 operating system, CDs are auto-mounted with the `-noexec` mount option. This option does not allow you to run any executable from the CD. To fix this problem, you need to unmount the CD, then manually remount the CD-ROM, and then run executables. The command to unmount the CD-ROM is:

```
# umount <cd device node>
```

The command to manually mount the CD is:

```
# mount <cd device node> <directory to be mounted>
```

Host Installation

Follow these steps to install MD Storage Manager software on a system physically connected to the storage array.

- 1 If necessary, install the SAS 5/E Adapter Driver.
 - a Type `2` on the main menu and press Enter.
 - b Press any key to return to the main menu when the **Installation Status** screen indicates that the installation has finished.
 - c Type `q` and press Enter.
-  **NOTICE:** The system must be restarted after installing the SAS 5/E driver and before manually installing the RDAC MPP driver.
 - d Restart the system and run the install script from the CD again.
- 2 At the CD main menu, type `3` and press Enter.

The installation wizard appears.

- 3** Click **Next**.
- 4** Accept the terms of the License Agreement and click **Next**.
- 5** Select a type of installation:
 - **Typical (Full installation)** — This package installs both the management station and host options. It includes the necessary host-based storage agent, multipath driver, and MD Storage Manager software. Select this option if the host will configure, manage, and monitor the storage array.
 - **Host** — This package installs the necessary storage agent and multipath driver on a host connected to the storage array. Select this option on all hosts that connect to a storage array but will not use MD Storage Manager.
- 6** Click **Next**.
- 7** If the **Overwrite Warning** dialog appears, click **OK**. The software currently being installed automatically replaces any existing versions of MD Storage Manager.
- 8** The **Multipath Warning** dialog box may appear to advise that this installation requires an RDAC MPP driver. If this screen appears, click **OK**. Installation instructions for the RDAC MPP driver are given in step 12.
- 9** If you selected typical (full) installation in step 5, a screen appears asking whether to restart the event monitor automatically or manually after rebooting. You should configure only one system (either a host or a management station) to automatically restart the event monitor.
 -  **NOTE:** The event monitor notifies the administrator of problem conditions with the storage array. MD Storage Manager can be installed on more than one system, but running the event monitor on multiple systems can cause multiple alert notifications to be sent for the same error condition. To avoid this issue, enable the event monitor only on a single system which monitors your MD3000 arrays. For more information on alerts, the event monitor, and manually restarting the event monitor, see the MD Storage Manager *User's Guide*.
- 10** The **Pre-Installation Summary** screen appears showing the installation destination, the required disk space, and the available disk space. If the installation path is correct, click **Install**.

- 11 When the installation completes, click **Done**.
- 12 Return to the CD main menu and select **View RDAC MPP Driver Installation Instructions**.
- 13 After installation of the RDAC driver is complete, restart the system.
- 14 Install MD Storage Manager on all other hosts attached to the MD3000 array.
- 15 Reboot each host attached to the array.

Management Station Installation

Follow these steps to install MD Storage Manager on a system that configures and manages a storage array over the network.

- 1 At the CD main menu, type 3 and press Enter. The installation wizard appears.
- 2 Click **Next**.
- 3 Accept the terms of the License Agreement and click **Next**.
- 4 Select **Management Station** as the type of installation. This option installs only the MD Storage Manager software used to configure, manage and monitor a MD3000 storage array.
- 5 Click **Next**.
- 6 If the **Overwrite Warning** dialog appears, click **OK**. The software currently being installed automatically replaces any existing versions of MD Storage Manager.
- 7 A screen appears asking whether to restart the event monitor automatically or manually after rebooting. You should configure only one system (either a host or a management station) to automatically restart the event monitor.



NOTE: The event monitor notifies the administrator of problem conditions with the storage array. MD Storage Manager can be installed on more than one system, but running the event monitor on multiple systems can cause multiple alert notifications to be sent for the same error condition. To avoid this issue, enable the event monitor only on a single system which monitors your MD3000 arrays. For more information on alerts, the event monitor, and manually restarting the event monitor, see the MD Storage Manager *User's Guide*.

- 8 The **Pre-Installation Summary** screen appears, showing the installation destination, the required disk space, and the available disk space. If the installation path is correct, click **Install**.
- 9 When the installation completes, click **Done**.
A screen appears asking if you want to restart the system now.
- 10 Restart the system.
- 11 Set the path for the command line interface (CLI), if required. See the *MD Storage Manager CLI Guide* for more information.

Documentation for Windows Systems

Viewing the *PowerVault MD Documentation CD* Contents

- 1 Insert the CD. If autorun is disabled, navigate to the CD and double-click `setup.exe`.



NOTE: On a server running Windows Server 2008 Core version, navigate to the CD and run the `setup.bat` utility. Installing and viewing documentation other than the MD3000 Readme is not supported on Windows Server 2008 Core version.

A screen appears showing the following items:

```
View MD3000 Readme
View Product Documentation
Install MD3000 Documentation
```

- 2 To view the `readme.txt` file, click the first bar.
The `readme.txt` file appears in a separate window.
- 3 Close the window after viewing the file to return to the menu screen.
- 4 To view the manuals from the CD, open the HTML versions from the `/docs` folder on the CD, or select **View Product Documentation**.

Installing the Manuals

- 1 Insert the CD, if necessary, and select **Install MD3000 Documentation** in the main menu.
A second screen appears.

- 2 Click **Next**.
- 3 Accept the License Agreement and click **Next**.
- 4 Select the installation location or accept the default and click **Next**.
- 5 Click **Install**.
The installation process begins.
- 6 When the process completes, click **Finish** to return to the main menu.
- 7 To view the installed documents, go to **My Computer** and navigate to the installation location.



NOTE: Installing MD3000 Documentation is not supported on Windows Server 2008 Core Version.

Documentation for Linux Systems

Viewing the *PowerVault MD Documentation CD Contents*

- 1 Insert the CD.
For some Linux distributions, a screen appears asking if you want to run the CD. Select **Yes** if the screen appears. If no screen appears, execute `./install.sh` within the **linux** folder on the CD.
- 2 A menu screen appears showing the following items:
 - 1 - View MD3000 Readme
 - 2 - Install MD3000 Documentation
 - 3 - View MD3000 Documentation
 - 4 - Dell Support
 - 5 - View End User License Agreement
- 3 If you want to view the **readme.txt** file, type `1` and press Enter.
The file appears in a separate window. Close the window after viewing the file to return to the menu screen.

- 4 To view another document, type 3 and press Enter.
A second menu screen appears with the following selections:
 - MD3000 Owner's Manual
 - MD3000 Installation Guide
 - MD Storage Manager CLI Guide
 - MD Storage Manager User's Guide
 - SAS 5/E Adapter User's Guide

 **NOTE:** To view the documents from the CD, you must have a web browser installed on the system.

- 5 Type the number of the document you want and press Enter.
The document opens in a browser window.
- 6 Close the document when finished.
- 7 Select another document or type `q` and press Enter to quit. The system returns to the main menu screen.

Installing the Manuals

- 1 Insert the CD, if necessary, and from the menu screen, type 2 and press Enter.
- 2 A screen appears showing the default location for installation. Press Enter to accept the path shown, or enter a different path and press Enter.
- 3 When installation is complete, press any key to return to the main menu.
- 4 To view the installed documents, open a browser window and navigate to the installation directory.

4

Post-Installation Tasks

Before using the MD3000 storage array for the first time, you must complete a number of initial configuration tasks in the order shown. These tasks can be performed from any system (host or management station) on which you have installed MD Storage Manager software.

 **NOTE:** Advanced Configuration for MD Storage Manager (Tools→ Change Network Configuration→ Configure Ethernet Management Ports) should *only* be attempted with Dell technical assistance.

- 1 For out-of-band management, you must set the network configuration for each RAID controller module, including its Internet Protocol (IP) address, subnetwork mask (subnet mask), and gateway.

 **NOTE:** You can set the network configuration using a DHCP server.

- 2 Start MD Storage Manager.

- On Microsoft® Windows® operating systems, select **Start**, and, depending on your version of Windows, select either **All Programs** or **Programs**. From the program list, select **Dell MD Storage Manager→ Modular Disk Storage Manager Client**.
- On Linux operating systems, click the MD Storage Manager desktop icon.

 **NOTE:** You can also launch MD Storage Manager in Linux by entering the following commands at the command prompt:

```
cd /opt/dell/mdstoragemanager/client
./SMclient
```

- 3 The **Add New Storage Array** screen appears asking if you want to search for attached storage arrays. Click **OK** to select Automatic Discovery, the default.

 **NOTE:** It may take several minutes for the discovery process to complete. Closing the **Automatic Discovery** status window before then stops the discovery process.

After discovery is complete, a confirmation screen appears. Click **Close** to close the screen.

- 4 The name of the first storage array found appears beneath the title area of MD Storage Manager. To see a list of all storage arrays found on the local network, click the down arrow next to the storage array name. If this list is not accurate, see "Verifying Storage Array Discovery" on page 41 for more information.
- 5 The default name for a newly installed MD3000 Storage Array is "Unnamed". If another name appears in MD Storage Manager, click the down arrow next to the name and click **Unnamed** in the drop-down list.
- 6 Five tabs appear in the area beneath the name of the selected array. Click the **Summary** tab to see information on the selected array.
- 7 Click the **Perform Initial Setup Tasks** link to see an outline and links to the remaining post-installation tasks. For more information about each task, see the *MD Storage Manager User's Guide*. Perform these tasks in the order shown in Table 4-1.



NOTE: Before configuring the storage array, check the status icons on the **Summary** tab to make sure the enclosures in the storage array are in an **Optimal** status. For more information on the status icons, see "Troubleshooting Tools" on page 45.

Table 4-1. Initial Setup Tasks Dialog Box

Task	Purpose	Information Needed
Rename the storage array. NOTE: If you need to physically find the device, click Blink the storage array on the Initial Setup Tasks dialog box or click the Tools tab and choose Blink . Lights on the front of the storage array blink intermittently to identify the array. Dell recommends blinking storage arrays to ensure that you are working on the correct enclosure.	To provide a more meaningful name than the software-assigned label of Unnamed	A unique, clear name with no more than 30 characters that may include letters, numbers, and no special characters other than underscore (_), minus (-), or pound sign (#) NOTE: MD Storage Manager does not check for duplicate names. Names are not case sensitive.

Table 4-1. Initial Setup Tasks Dialog Box (continued)

Task	Purpose	Information Needed
Set a storage array password.	To restrict unauthorized access, MD Storage Manager asks for a password before changing the configuration or performing a destructive operation	Case-sensitive password that meets your security standards
Set up alert notifications. Set up e-mail alerts. Set up SNMP alerts.	To arrange to notify individuals (by e-mail) and/or storage management stations (by SNMP) when a storage array component degrades or fails, or an adverse environmental condition occurs	E-mail — Sender (sender's SMTP gateway and e-mail address) and recipients (fully qualified e-mail addresses) SNMP — (1) community name, a known set of storage management stations, set by administrator as an ASCII string in the management console (default: "public") and (2) trap destination, IP address or host name of a management console running an SNMP service

NOTE: The Notification Status line in the Summary screen Status area shows if alerts have been set for the selected array.

Table 4-1. Initial Setup Tasks Dialog Box (continued)

Task	Purpose	Information Needed
Configure host access.	Allow access to virtual disks for certain or all hosts	Host and host group names, types, and operating systems HBA host port ID numbers, if necessary NOTE: You may need to refer to the documentation that came with your cards to identify the host ports. For maximum redundancy, select all HBAs connected to the array during manual setup. For example, a host might have two HBAs, each connected to the array. Specify each connected HBA host port.
Configure storage array (2 options). Automatic configuration Manual configuration	To allow you to create virtual disks, to map them to hosts, and to create hot spares to automatically replace physical disks marked as Failed. Choose the items under Automatic configuration if you want uniformly sized virtual disks of the same RAID level.	Automatic — (1) Uniform RAID level and (2) host names for mapping Manual — (1) Whether virtual disk uses unconfigured space or free capacity, (2) physical disk type, (3) size, and (4) RAID level

- 8** Register the virtual disks and the disk groups with the hosts to allow activity between them.

For a Linux host:

- Use the `hot_add` utility located in `/usr/sbin`. The `hot_add` utility registers newly created virtual disks with the operating system without rebooting the host. The `hot_add` utility is installed with the host package and runs on the host operating system console.

For Windows, virtual disks are automatically registered.

- 9 If you have purchased premium features, you can set them up at this point. Click **Tools**→ **View/Enable Premium Features** or **View and Enable Premium Features** on the **Initial Setup Tasks** dialog box. See "Premium Features" on page 45 for more information.

Verifying Storage Array Discovery

The Automatic Discovery option automatically discovers both in-band and out-of-band arrays and adds the storage arrays to the management domain. If the out-of-band or in-band connections shown on the **Summary** page are not accurate, complete the following steps. For more information, refer to the *MD Storage Manager User's Guide* or MD Storage Manager online help.

- 1 Check the hardware and connections for possible problems. For specific procedures on troubleshooting interface problems, see the *Dell PowerVault MD3000 Hardware Owner's Manual*.
- 2 Verify that the array is on the local subnetwork. If it is not, click the **New** link to manually add it.
- 3 Verify that the status of each storage array is Optimal. If any array shows an Unresponsive status, complete one of the following steps:
 - To remove the array from the management domain, highlight the array and then click the **Remove** link.
 - To add an array, click the **New** link.
On Linux, click the **Manual** button and click **OK**.
- 4 If the array still shows an Unresponsive status, contact Technical Assistance.

Load Balancing

Load Balance Policy

Multi-path drivers select the I/O path to a virtual disk through a specific RAID controller module. When the multi-path driver receives a new I/O, the driver tries to find a path to the current RAID controller module that owns the virtual disk. If that path cannot be found, the multi-path driver migrates the virtual disk ownership to the secondary RAID controller module. When multiple paths to the RAID controller module that owns the virtual disk exist,

you can choose a load balance policy to determine which path is used to process I/O. Multiple options for setting the load balance policies let you optimize I/O performance when mixed host interfaces are configured.

You can choose one of these load balance policies to optimize I/O performance:

- Round robin with subset
- Least queue depth with subset
- Least path weight with subset (Microsoft Windows operating systems only)

Round Robin with Subset

The round-robin with subset I/O load balance policy routes I/O requests, in rotation, to each available data path to the RAID controller module that owns the virtual disks. This policy treats all paths to the RAID controller module that owns the virtual disk equally for I/O activity. Paths to the secondary RAID controller module are ignored until ownership changes. The basic assumption for the round-robin policy is that the data paths are equal. With mixed host support, the data paths might have different bandwidths or different data transfer speeds.

Least Queue Depth with Subset

The least queue depth with subset policy is also known as the least I/Os, or least requests, policy. This policy routes the next I/O request to a data path that has the least outstanding I/O requests queued. For this policy, an I/O request is simply a command in the queue. The type of command or the number of blocks that are associated with the command are not considered. The least queue depth with subset policy treats large block requests and small block requests equally. The data path selected is in the path group of the RAID controller module that owns the virtual disk.

Least Path Weight with Subset

The least path weight with subset policy assigns a weight factor to each data path to a virtual disk. An I/O request is routed to the path with the lowest weight value to the RAID controller module that owns the virtual disk. If more than one data path to the virtual disk has the same weight value, the

round-robin with subset path selection policy is used to route I/O requests between paths with the same weight value. The least path weight with subset load balance policy is not supported on Linux operating systems.

Setting Load Balance Policies in Linux

Two options are available for setting the load balance policies for the Linux operating system:

- Using the **mppUtil** command
- Using the **mpp.conf** file

 **NOTE:** The only load balancing policy options for Linux are 0x0 (round robin) and 0x1 (least queue depth).

The **mppUtil** command includes the option of implementing the changes immediately; however, changes do not persist after rebooting the host.

- 1** Are you using the **mppUtil** command?
 - Yes – Go to step 2.
 - No – Go to step 5.
- 2** Do you want to implement the change immediately without having the change persist after rebooting the host?
 - Yes – Go to step 3.
 - No – Go to step 4.
- 3** Run this command:

```
mppUtil -o LoadBalancePolicy=n
```

where *n* is 0 for round robin or 1 for least queue depth. This change takes effect immediately and affects only the in-memory state of the load balance policy. The change will not persist after rebooting the host.

Once you have successfully run the **mppUtil** command, your load balancing steps are complete. You do not need to continue from here.

- 4** If you chose the **Yes** option in step 2 above, run this command:

```
mppUtil -o LoadBalancePolicy=n, SaveSettings
```

where *n* is 0 for round robin or 1 for least queue depth. The *SaveSettings* parameter lets the load balance setting persist after rebooting the host. Go to step 6 to complete the procedure.

- 5 Edit the `mpp.conf` file to update the `LoadBalancePolicy` variable. Set the `LoadBalancePolicy` variable to `0` for round robin or `1` for least queue depth. Go to step 6 to complete the procedure.
- 6 Run this command to make sure that the changes persist:
`mppUpdate`

The `mppUpdate` command rebuilds the RAM disk image with the new load balance policy settings. The new settings will be used after rebooting the host.

Changing Load Balance Policies in Windows 2008

Load balancing with the MD3000 is only available for Windows Server 2008 and later versions of the operating system. You can change the load balance policies from the default round robin with subset by using one of the following:

- Device Manager options (see step 1 through step 4)
- Disk Management options (see step 5 through step 8)

Changing the Load Balance Policy Using Windows 2008 Device Manager Options

- 1 From the desktop of the host, right-click the **My Computer** icon and select **Manage** to open the **Computer Management** dialog.
- 2 Click **Device Manager** to show the list of devices attached to the host.
- 3 Right-click the multi-path disk device for which you want to set load balance policies, then select **Properties**.
- 4 From the **MPIO** tab, select the load balance policy you want to set for this disk device.

Changing the Load Balance Policy Using the Windows 2008 Disk Management Options

- 5 From the desktop of the host, right-click the **My Computer** icon and select **Manage** to open the **Computer Management** dialog.
- 6 Click **Disk Management** to show the list of virtual disks are attached to the host.
- 7 Right-click the virtual disk on which you want to set the load balance policy, then click **Properties**.

- 8 From the **MPIO** tab, select the load balance policy that you want to set for this virtual disk.

Premium Features

Premium features supported by MD Storage Manager include:

- Snapshot
- Enhanced Snapshot
- Snapshot and Virtual Disk Copy
- Enhanced Snapshot and Virtual Disk Copy
- Virtual Disk Copy

To install and enable these premium features, you must first purchase a feature key file for each feature and then specify the storage array that will host them. The *Premium Feature Activation Card* that shipped in the same box as your MD3000 gives instructions for this process.

For more information on using these premium features, see the *MD Storage Manager User's Guide*.

Troubleshooting Tools

The MD Storage Manager establishes communication with each managed array and determines the current array status. When a problem occurs on a storage array, MD Storage Manager provides several ways to troubleshoot the problem:

- **Recovery Guru** — The Recovery Guru diagnoses critical events on the storage array and recommends step-by-step recovery procedures for problem resolution. To access the Recovery Guru using MD Storage Manager, click **Support** → **Recover from Failure**. The Recovery Guru can also be accessed from the **Status** area of the **Summary** page.



NOTE: A SAS Device Miswire Recovery Guru condition can be generated by connecting the host port of one controller to the unused expansion port on the other controller in a MD3000 enclosure. After fixing the miswire condition, power cycle the MD3000 to clear the Recovery Guru condition.

- **Storage Array Profile** — The Storage Array Profile provides an overview of your storage array configuration, including firmware versions and the current status of all devices on the storage array. To access the Storage Array Profile, click **Support**→ **View storage array profile**. The profile can also be viewed by clicking the **Storage array profile** link in the **Hardware Components** area of the **Summary** tab.
- **Status Icons** — Status icons identify the six possible health status conditions of the storage array. For every non-Optimal status icon, use the Recovery Guru to detect and troubleshoot the problem.
 - **Optimal** — Every component in the managed array is in the desired working condition.
 - **Needs Attention** — A problem exists with the managed array that requires intervention to correct it.
 - **Fixing** — A Needs Attention condition has been corrected and the managed array is currently changing to an Optimal status.
 - **Unresponsive** — The storage management station cannot communicate with the array, one controller, or both controllers in the storage array. Wait at least five minutes for the storage array to return to an Optimal status following a recovery procedure.
 - **Contacting Device** — MD Storage Manager is establishing contact with the array.
 - **Needs Upgrade** — The storage array is running a level of firmware that is no longer supported by MD Storage Manager.
- **Support Information Bundle** — The **Gather Support Information** link on the **Support** tab saves all storage array data, such as profile and event log information, to a file that you can send if you seek technical assistance for problem resolution. It is helpful to generate this file before you contact Dell support with MD3000-related issues.

Uninstalling Software

The following sections contain information on how to uninstall MD Storage Manager software from both host and management station systems.

Uninstalling From Windows

Use the Change/Remove Program feature to uninstall MD Storage Manager using Microsoft® Windows® operating systems other than Windows Server 2008.

- 1 From the **Control Panel**, double-click **Add or Remove Programs**.
- 2 Select **MD Storage Manager** from the list of programs.
- 3 Click **Change/Remove**, and follow the prompts to complete the uninstallation process.

The **Uninstall Complete** window appears.

- 4 Select **Yes** to restart the system, and then click **Done**.

Use the following procedure to uninstall MD Storage Manager on Windows Server 2008 GUI versions.

- 1 From the **Control Panel**, double-click **Programs and Features**.
- 2 Select **MD Storage Manager** from the list of programs.
- 3 Click **Uninstall/Change**, and follow the prompts to complete the uninstallation process.

The **Uninstall Complete** window appears.

- 4 Select **Yes** to restart the system, and then click **Done**.

Use the following procedure to uninstall MD Storage Manager on Windows Server 2008 Core versions.

- 1 Navigate to the **C:\Program Files\Dell\MD Storage Manager\Uninstall Dell_MD_STORAGE_MANAGER** directory.

By default, MD Storage Manager is installed in the **C:\Program Files\Dell\MD StorageManager\Uninstall Dell_MD_STORAGE_MANAGER** directory. If another directory was

used during installation, navigate to that directory before beginning the uninstall procedure.

- 2 In the installation directory, enter the following case-sensitive command:
`Uninstall Dell_MD_Storage_Manager`
- 3 In the **Uninstall** window, click **Next** and follow the instructions that appear on the screen.
- 4 Select **Yes** to restart the system, and then click **Done**.

Uninstalling From Linux

Use the following procedure to uninstall MD Storage Manager from a Linux system.

- 1 Navigate to the
`/opt/dell/mdstoragemanager/Uninstall_dell_Mdstoragemanager` directory.
By default, MD Storage Manager is installed in the
`/opt/dell/mdstoragemanager/Uninstall_dell_Mdstoragemanager` directory.
If another directory was used during installation, navigate to that directory before beginning the uninstall procedure.
- 2 From the installation directory, enter the following case-sensitive command:
`./Uninstall_dell_mdstoragemanager`
- 3 From the **Uninstall** window, click **Next**, and follow the instructions that appear on the screen.
While the software is uninstalling, the **Uninstall** window is displayed.
When the uninstall procedure is complete, the **Uninstall Complete** window is displayed.
- 4 Click **Done**.

Index

A

alerts, 39
Automatic Discovery, 37, 41

C

cabling, 9
 enclosure, 10-20
cluster host
 setting up, 28
cluster node
 reconfiguring, 28

D

disk group, 6, 40
documentation
 manuals, 34, 36

E

event monitor, 28, 31, 33

H

HBA, 25, 40
host bus adapter

See *HBA*

hot spares, 7, 9, 40

I

installation
 Linux, 30-33
 Windows, 26-30

L

Linux, 25, 34, 37, 48
load balancing
 policy, 41
 for Linux, 43
 for Windows, 44

P

password, 39
post-installation
 configuration, 37-38, 41
premium features, 9

R

RAID, 6
RDAC MPP driver, 31

readme, 33, 35
Recovery Guru, 45
Resource CD, 26, 28, 34, 36

S

Snapshot, 45
 enhanced, 45
Snapshot and Virtual Disk
 Copy, 45
 enhanced, 45
Snapshot Virtual Disk, 9
status, 38, 41, 46
status icons, 38, 46
storage array, 6
Storage Array Profile, 46

U

uninstalling
 Linux, 48
 Windows, 47

V

virtual disk, 6, 9, 40
Virtual Disk Copy, 9, 45
Volume Shadow-copy Service
 See VSS
VSS, 28

W

Windows, 25, 33, 37, 47